

**DETALHE - SAPATA**

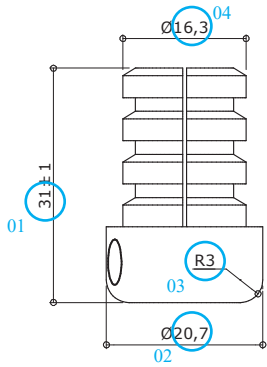

**VISTA 2**  
ESC. 1 : 1

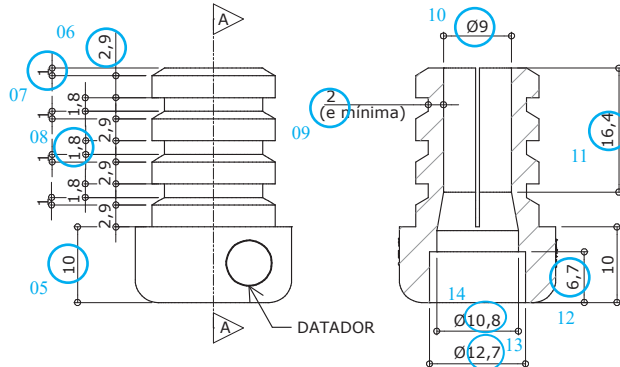

**VISTA 1**  
ESC. 1 : 1

**CORTE AA**  
ESC. 1 : 1

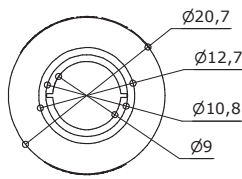

**VISTA INFERIOR**  
ESC. 1 : 1

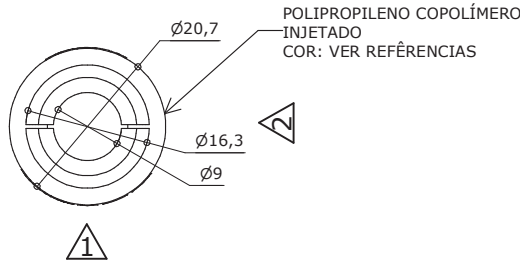

**VISTA SUPERIOR**  
ESC. 1 : 1

**SAPATA**

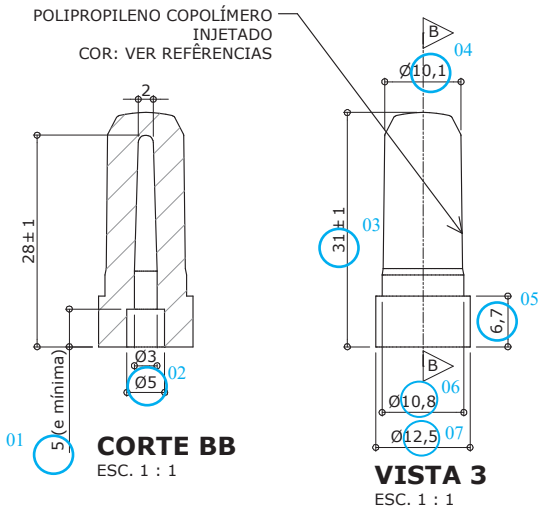

**CORTE BB**  
ESC. 1 : 1

**VISTA 3**  
ESC. 1 : 1

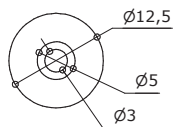

**VISTA INFERIOR**  
ESC. 1 : 1

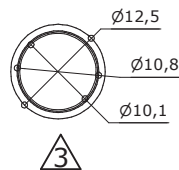

**VISTA SUPERIOR**  
ESC. 1 : 1

**PINO EXPANSOR**

Apresentar em relevo no material injetado a seguinte informação:



nome do fabricante do componente

**Identificação do Modelo**

Datador conforme figura abaixo:

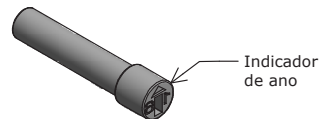
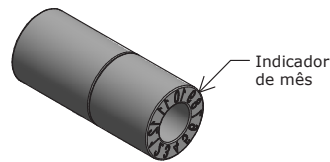
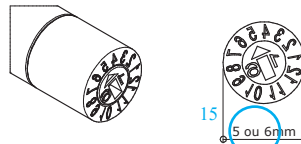

Datador duplo com miolo giratório D= 5 ou 6mm

**06B\_SP**  
**06B\_PE**

Sapata / Ponteira e Pino expensor da cadeira c/ datador modificado

Revisão 1  
Data 15/05/24

1/1



**Atenção**  
Preserve a escala  
Quando for imprimir, use folhas A4 e desabilite a função "Fit to paper"

Respeite o Meio Ambiente.  
Imprima somente o necessário

